



INSTALLATION, OPERATION AND MAINTENANCE INSTRUCTIONS

REAR ACCESS, LED TYPE T8 4 FT 4 LAMP 241 SERIES LED LIGHT FIXTURES FOR SPRAY PAINT BOOTH APPLICATIONS - CLEAN ROOMS

WARNING!

1. TO PREVENT THE RISK OF ELECTRICAL SHOCK DEACTIVATE/DISCONNECT THE POWER SUPPLY BEFORE INSTALLING OR RELAMPING FIXTURE.
2. THE BALLAST IN THIS FIXTURE IS DESIGNED TO OPERATE ON GROUNDED NEUTRAL SYSTEMS ONLY.
3. THIS FIXTURE SHOULD BE INSTALLED BY QUALIFIED TECHNICIANS IN STRICT ACCORDANCE WITH THE NATIONAL ELECTRICAL CODE AND ANY LOCAL REQUIREMENTS.

PAINT SPRAY BOOTH APPLICATIONS

The fixture should be sealed in such a way that only the face of the light fixture is exposed to the paint environment and the sides and rear are located in the Class I Division 2 environment.

OPERATIONAL DATA

Operate this fixture at its rated voltage. See fixture label for data. Do not install where the marked operating temperature exceeds the ignition temperature of the hazardous atmospheres.

MAINTENANCE DATA

1. Although no routine maintenance is required to keep this fixture functional, it should be checked periodically to ensure that it is working properly and to look for any external damage.
2. For optimum performance, keep light transmission parts of fixture clean. Any commercial glass cleaner can be used to clean the glass.
3. To Re-lamp: disconnect supply circuit. Remove qty 3 fasteners from rear access door opposite side from hinge. The door will swing open. Replace old lamp with new lamp. Close door and install fasteners in door to seal.
4. In the event of glass breakage, it will be necessary to replace the damaged glass in order to maintain the integrity of the fixture.

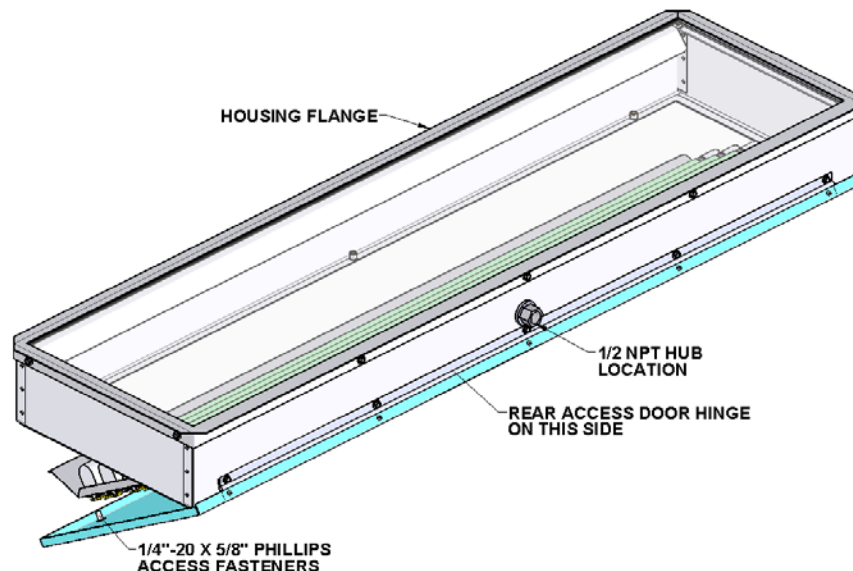

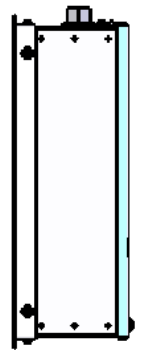
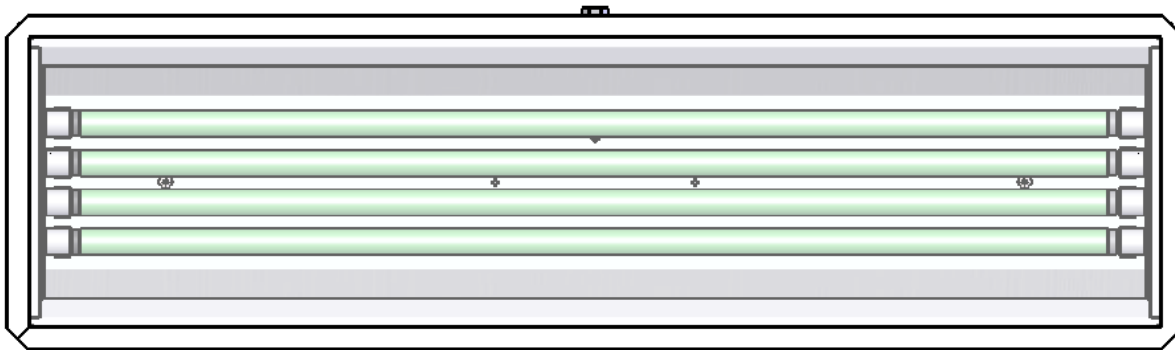
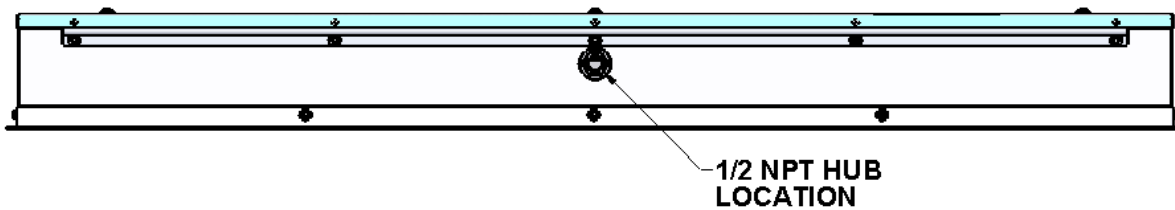
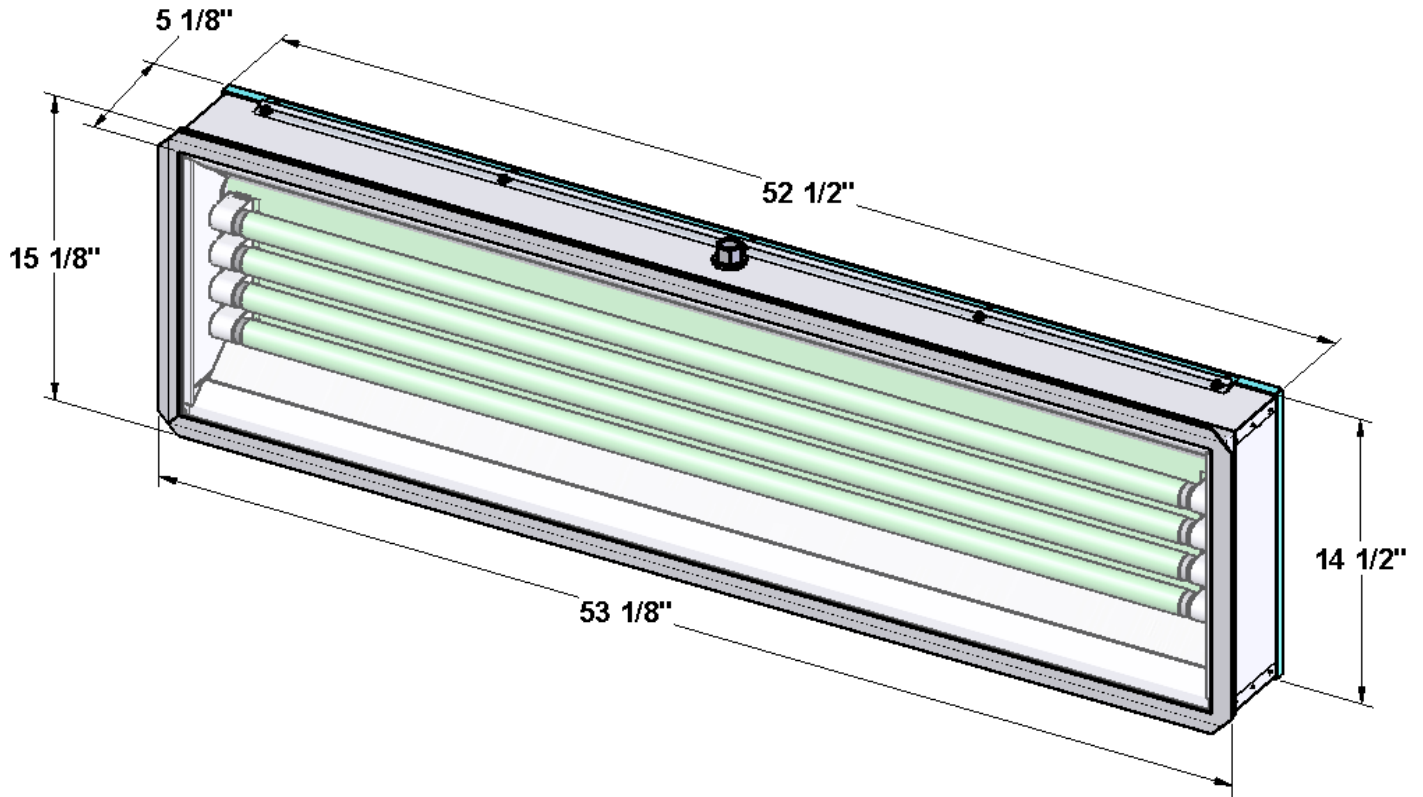

INSTALLATION

1. For horizontal mounting, mount with hinge on top side.

NOTE: Before installing fixture, make certain mounting gasket is installed on bottom surface of light mounting flange. Install mounting fasteners (not provided) and secure to booth panel. Customer is responsible for providing any panel reinforcements needed for mounting.

2. Caulk the flange perimeter with the same type of caulk as the spray booth.

3. Wire fixture through conduit hub according to schematic on back of ballast.

4. Remove (3) ¼"-20 x 5/8" Phillips access fasteners, open access door, install lamps, close access door and install ¼"-20 x 5/8" Phillips access fasteners.

NOTE: When installing lamp – fixtures are rated for LED TYPE T8 lamps only.

5. Installation of light fixture onto panel is now complete.

**WIRING SCHEMATIC FOR:
4 FT 4 LAMP LED TYPE T8 INSTANT START FIXTURE
COLOR TEMPERATURE (CCT): 4000K, 5000K**

LOW BALLAST FACTOR: INPUT AMPS: (120V: 0.42 AMPS)(277V: 0.18 AMPS)
WATTAGE:(50 WATTS)

NOM LUMEN OUTPUT: (5600(CCT 4000K)) (5800 (CCT 5000K))

STANDARD BALLAST FACTOR: INPUT AMPS: (120V: 0.48 AMPS)(277V: 0.21 AMPS)
WATTAGE:(58 WATTS)

NOMINAL LUMEN OUTPUT: (6400(CCT 4000K)) (6600 (CCT 5000K))

HIGH BALLAST FACTOR: INPUT AMPS: (120V: 0.62 AMPS)(277V: 0.28 AMPS)
WATTAGE:(74 WATTS)

NOMINAL LUMEN OUTPUT: (7400(CCT 4000K)) (8000 (CCT 5000K))

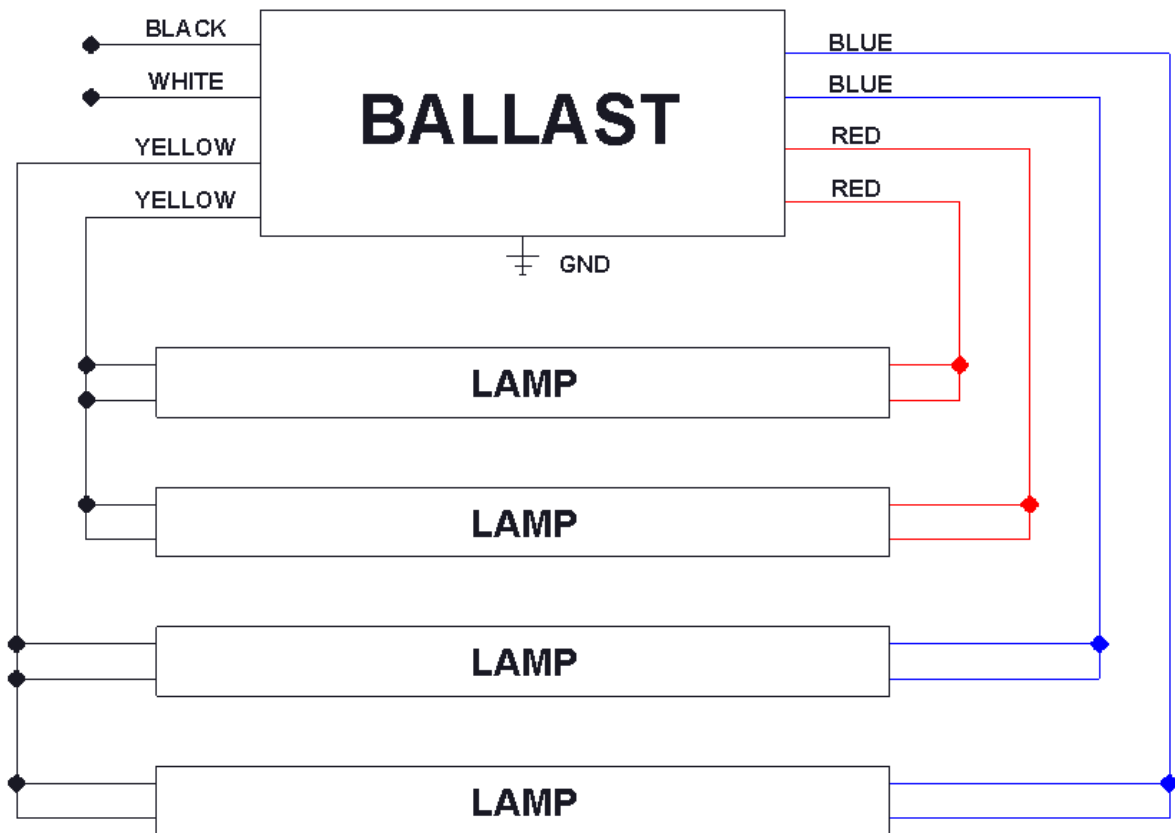

NOTE:

Refer to diagram on ballast with specific wiring details.

CAUTION:

THIS FIXTURE SHOULD BE INSTALLED BY QUALIFIED TECHNICIANS IN STRICT ACCORDANCE WITH THE NATIONAL ELECTRICAL CODE AND ANY LOCAL REQUIREMENTS

INSTALLATION INSTRUCTIONS FOR OUTSIDE ACCESS PANEL FRAME KIT P/N 4692 KIT NOT INCLUDED

1. Mark 12 ½" x 50 ½" hole on booth panel where fixture is to be located.
2. Cut hole in booth panel using suitable tools.
3. Install panel frames (Item #4 and Item #5) into hole in panel as shown in detail "A".
4. Install corner brackets (Item #3) to each corner where panel frames meet. Drill .129" (#30 bit) holes through corner brackets and panel frames and pop rivet in place using 1/8" pop rivets included with installation kit.
5. Install glass lens into panel frame.
 - A: Install ½ x ¾" open cell gasket (Item #6) around perimeter of panel frame as shown in section "A-A".
 - B: Install tempered glass lens (not included with kit) into panel frame and lock into place using glass clips (Item#2) with ¼"-20 hex head screws and ¼"-20hex nuts as shown in section "A-A".
6. Install light fixture into panel frame and lock into place using (4) light clips (Item #1) with ¼"-20 hex head screws and ¼"-20 hex nuts section "A-A".
7. Wire fixture through conduit hub according to schematic on back of ballast.
8. Remove (3) ¼"-20 x 5/8" Phillips access fasteners, open access door, install lamps, close access door and install ¼"-20 x 5/8" Phillips access fasteners.

NOTE: When installing lamp – **fixtures are rated for 32 watts T8 lamps only.**
9. Installation of light fixture onto panel is now complete.

ITEM NO.	DESCRIPTION	FINISHED QTY.	RAW QTY.	PART NUMBER
1	LIGHT CLIP	4		4694
2	GLASS CLIP	2		4695
3	CORNER BRACKET	4		4696
4	LIGHT FRAME IS 3/4	2		4697
5	LIGHT FRAME IS 1/2	2		4698
6	GAS KET 1/2 X 3/4	1	12.00	1641
7	MHGS 1/4-20 X .75 ZINC PLATED	10		4700
8	1/4-20 HEX NUT	10		4701
9	P.O.P. RIVET 1/8 X 1/2 LONG	8		3215
10	BAG 4" X 6" RECYCLABLE 2MIL POLY	1		1695

NOTE: (P/N 1706) CLEAR TEMPERED GLASS 3/16" X 15" X 53" IS OPTIONAL AND IS NOT INCLUDED IN KIT

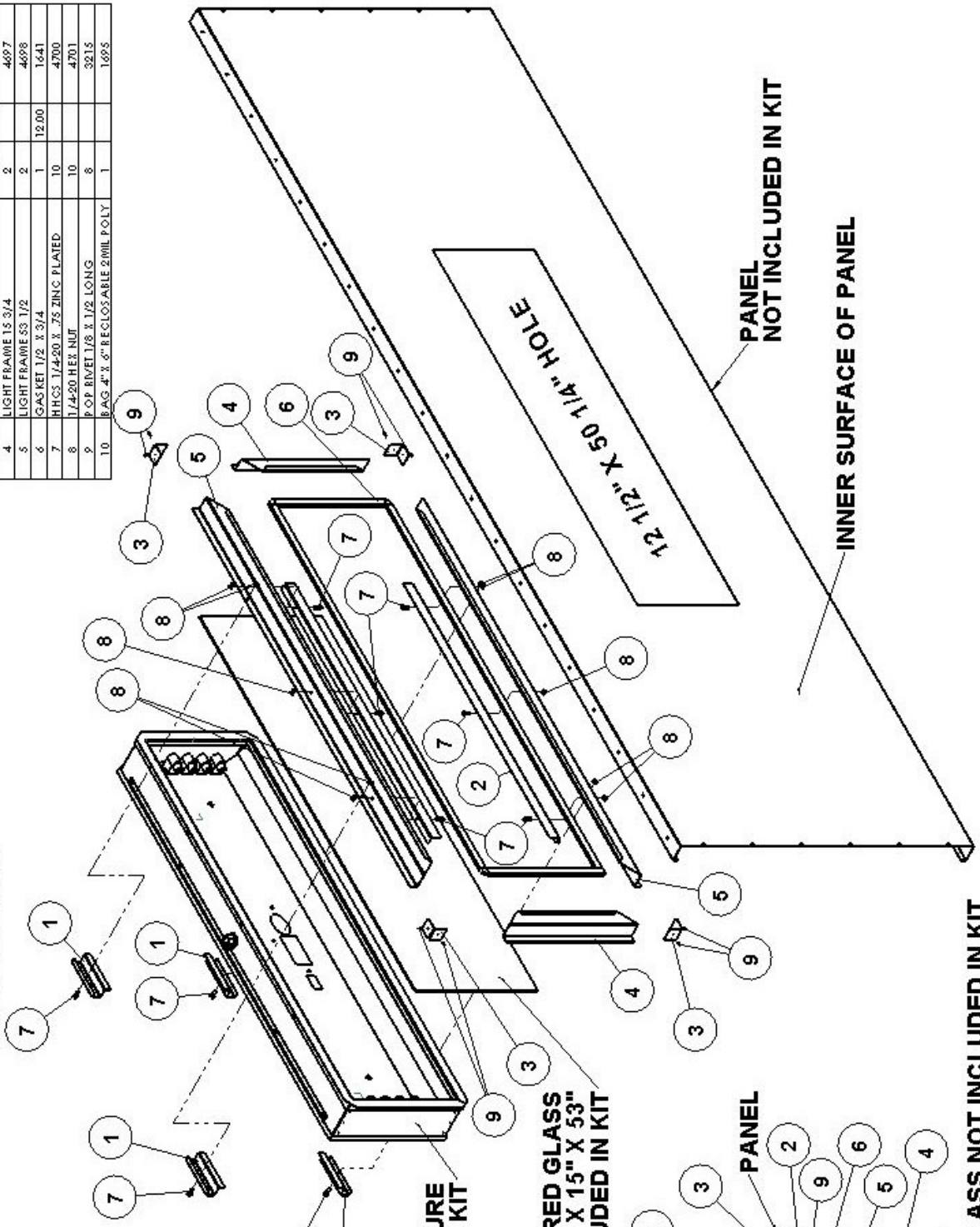
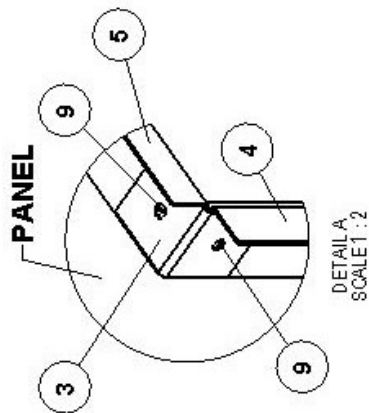

390241 FIXTURE NOT INCLUDED IN KIT

(P/N 1706) CLEAR TEMPERED GLASS 3/16" X 15" X 53" NOT INCLUDED IN KIT

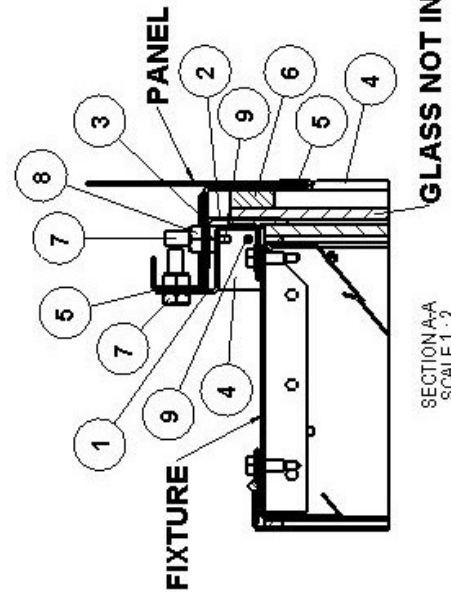

PANEL NOT INCLUDED IN KIT

INNER SURFACE OF PANEL

GLASS NOT INCLUDED IN KIT