

INSTALLATION INSTRUCTIONS FOR 8 FT. REAR ACCESS, PANEL MOUNT FLUORESCENT LIGHT FIXTURES FOR PAINT BOOTH APPLICATIONS

1. Mark a 19 5/8" x 100 5/8" hole on booth panel where fixture is to be located.
2. Cut hole in booth panel using suitable tools.
3. Place light fixture into hole in booth panel, center, and mark locations of (20) mounting holes.

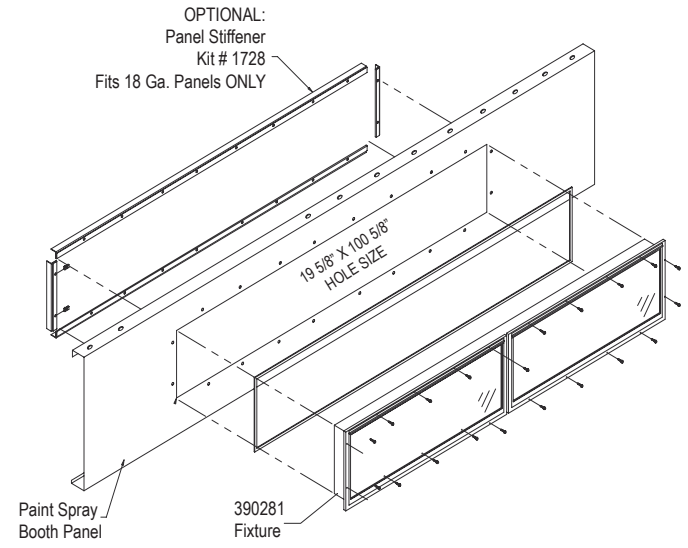

4. Remove fixture from booth panel and punch (20) 5/16" dia. mounting holes in panel.
5. Install light fixture into panel from inside of booth as shown.
NOTE: Before installing fixture, make certain mounting gasket is installed on bottom surface of light mounting flange.
Locate panel stiffeners on back side of booth panel and install (20) mounting screws through fixture and panel and tighten into U-nuts on panel stiffeners as shown.
6. Installation of light fixture into booth panel is now complete.
7. Wire fixture through conduit hub according to schematic on back of ballast.
8. This fixture should be installed by qualified technicians in strict accordance with the National Electrical Code and any local requirements.

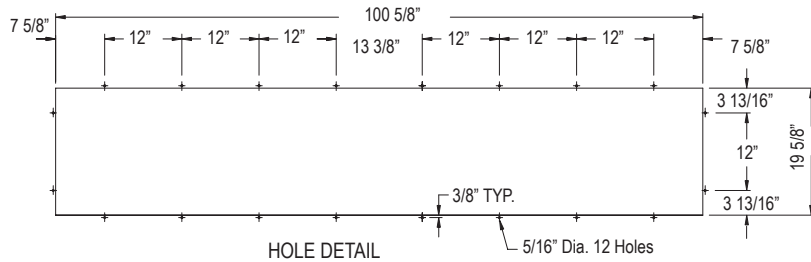
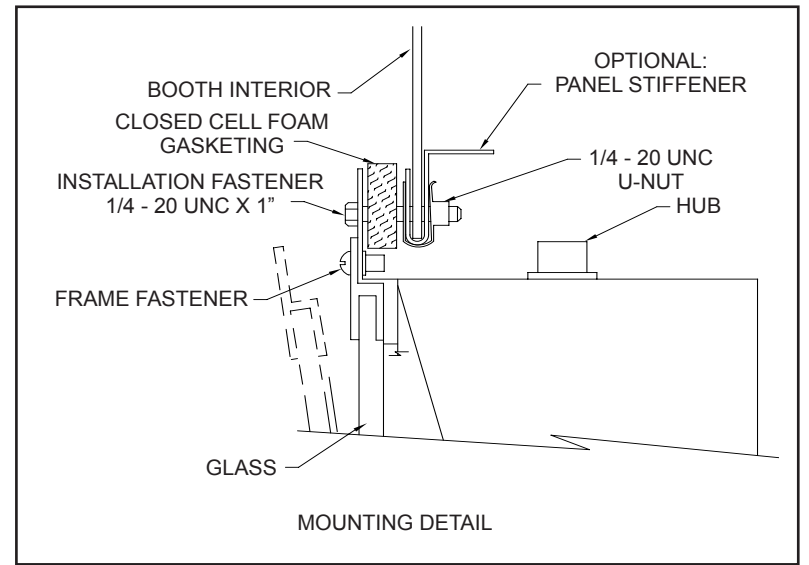

INSTALLATION INSTRUCTIONS FOR 8 FT. REAR ACCESS, PANEL MOUNT FIXTURE T8

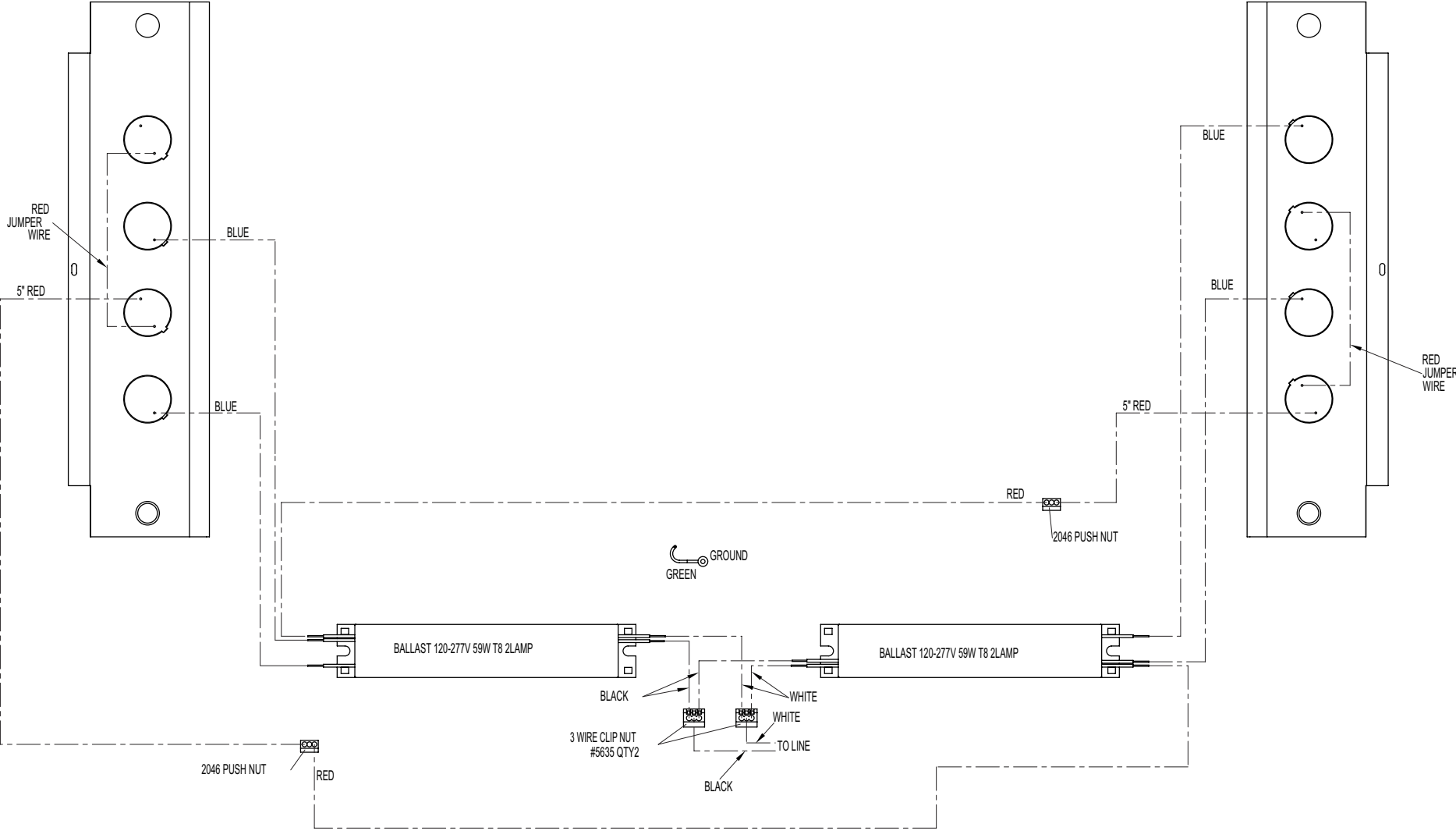

INSTALLATION INSTRUCTIONS FOR 8 FT. REAR ACCESS, PANEL MOUNT FIXTURE T8HO

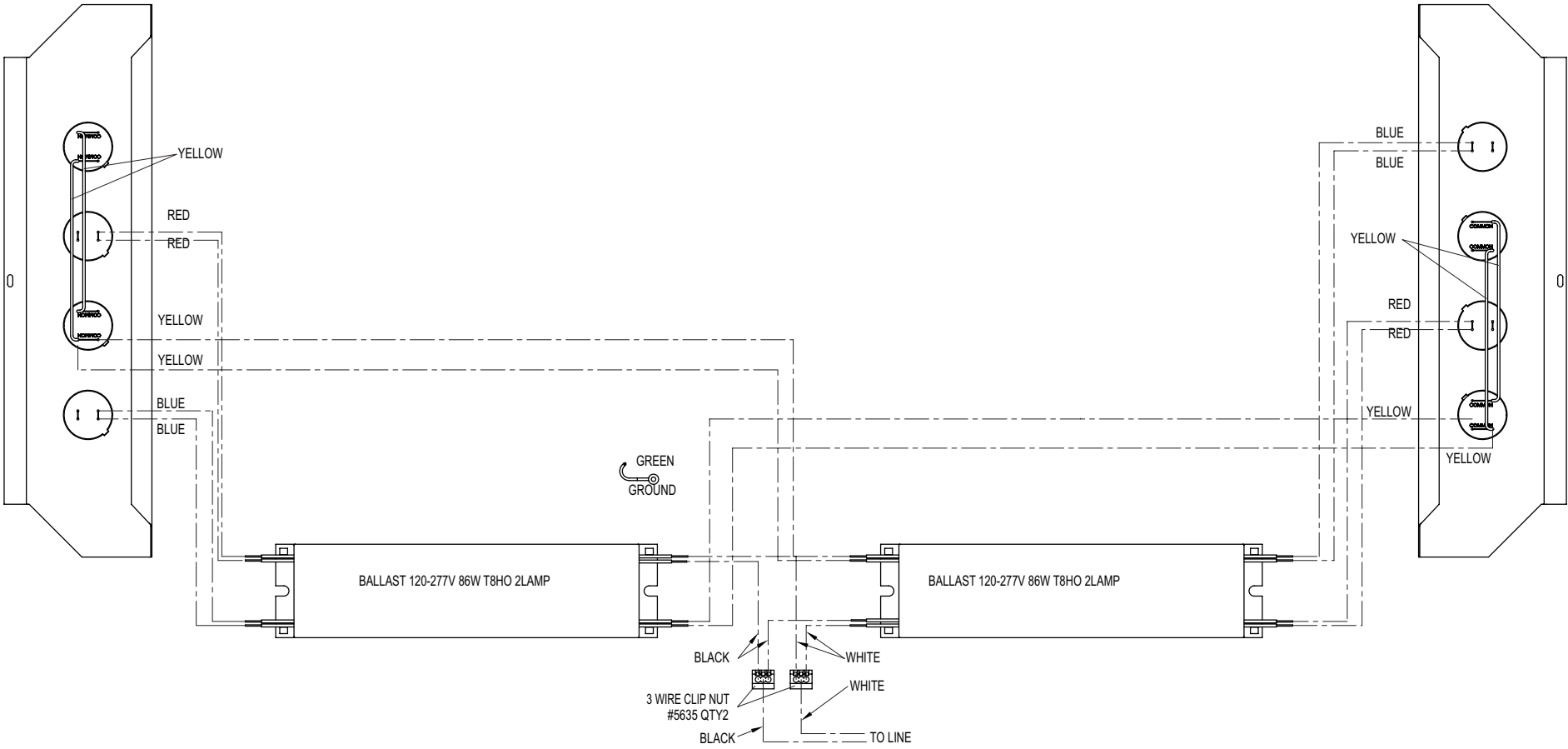

INSTALLATION INSTRUCTIONS FOR 8 FT. REAR ACCESS, PANEL MOUNT FIXTURE T12

