

INSPECTION

LIGHTING SERIES

DATE: _____ PROJECT MGR: _____

JOB: _____

PN: _____

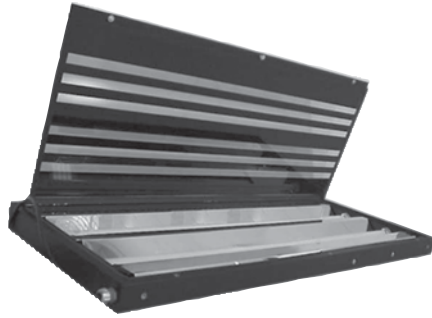

APPLICATIONS

Paint Inspection
Plastic Inspection
Defect Detection

The Inspection Series is a must for any surface finish inspection area! Fixture is constructed from a cold rolled steel one piece housing, with a 93% reflectance specular polished reflector. The lens design creates a well defined lamp image using light and dark contrasts that cause defects in the paint to show for ease of detection and repair. The series is available in 4 or 8' lengths. Optional stands are available to suit any inspection area needs. Horizontal and Vertical cart options (see Portable Lighting Section) also available. Lamps included.

SPECIFICATIONS

LISTINGS: ETL listed for U.S. and Canada
Class I Division 2 Groups A,B,C,D
T3C (160 degree C) operating code
Class II Division 2 Groups F & G
T3C (160 degree C) operating code
Conforms to UL 1598 and UL 844
Certified to CSA 22.2 No. 137 and 250



FEATURES: Slim 2 - 1/4" thick 1 piece housing made from 20 ga. CRS & powder coated black paint.
Front Access door frame.

LENS: 3/16" clear tempered glass with stripes.

ELECTRICAL: Available in 32 or 59 watt with T8 lamps
Voltages: 120-277

OPTIONS: ALL OPTIONS ORDERED SEPARATELY - see pages 79-80
Stationary mount kit #3564
Pivot hinge mount kit #3563
Swivel mount kit #4828 (For carts and 4 Ft. fixtures ONLY)
Clear glass lens
(Consult factory for cord and plug options)

| Series | Lamp | Lamp Qty | Hub | Order # | Voltage |
|-----------|--------|----------|----------|------------------|-----------------------|
| 39042LINS | T8 32W | 2 | 1/2" NPT | 39042LINS - 3613 | 120-277 Volts 50/60HZ |
| 39082LINS | T8 59W | 2 | 1/2"NPT | 39082LINS - 3281 | 120-277 Volts 50/60HZ |

LAMPS INCLUDED
(All Options Ordered Separately)

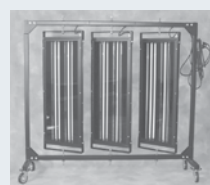

Vertical 3 fixture cart
See page: 83-84

INSPECTION LIGHTING



INSPECTION

LIGHTING SERIES

DIMENSIONS

4 Ft. 39042LINS

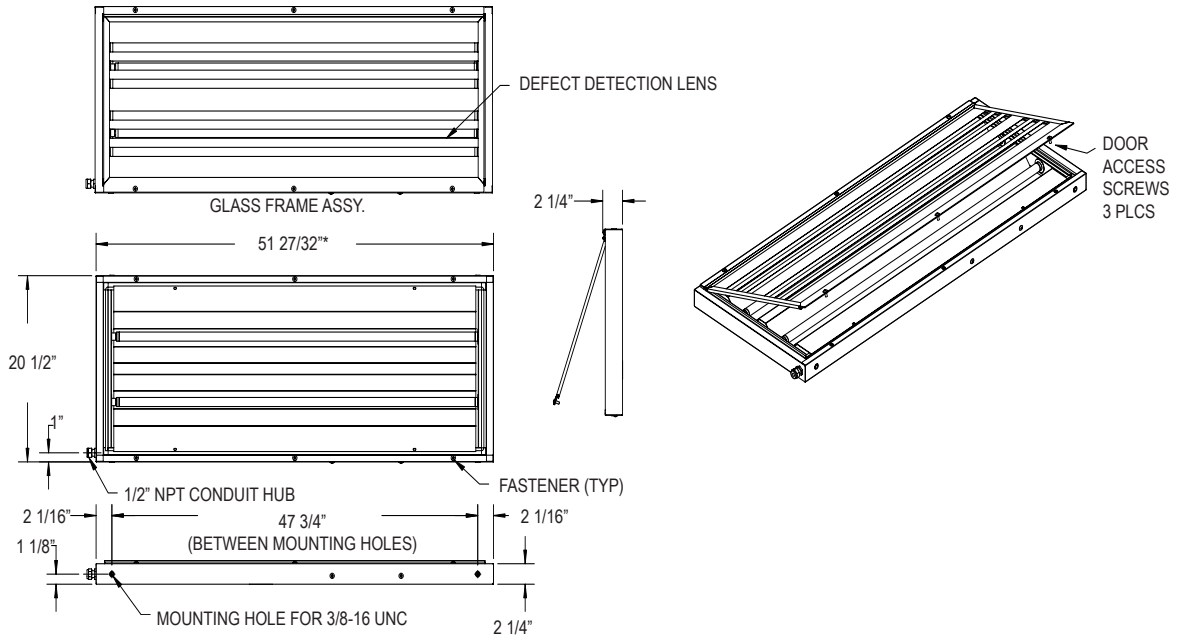

8 Ft. 39082LINS

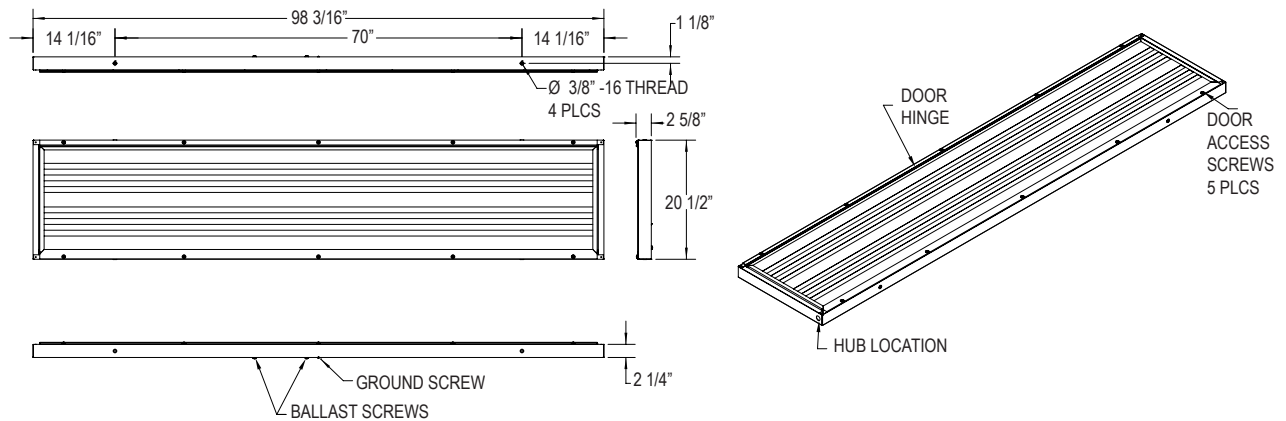

INSPECTION MOUNTS



www.ldpi-inc.com

FOR LDPI, Inc. INSPECTION FIXTURES

INSPECTION SERIES MOUNTING

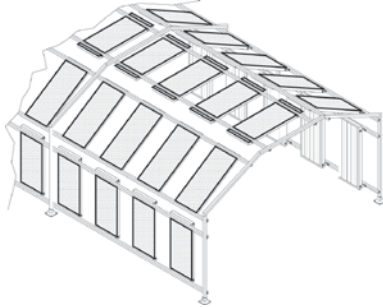

4 Ft. fixture top horizontal mount

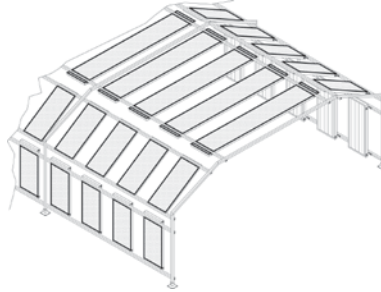

8 Ft. fixture top horizontal mount

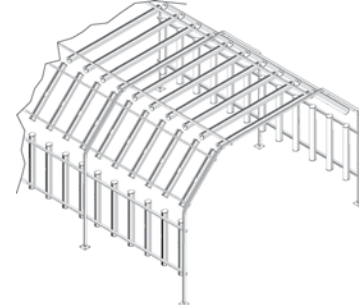

INS2 with 8 Ft. fixture top horizontal mount

Tunnel provides visual angles from all sides and can be designed with combinations of 4 Ft. and 8 Ft. fixtures to fit product and application requirements. Fixtures mounted 26 1/2" on center. INS2 fixtures mounted 18" on center.

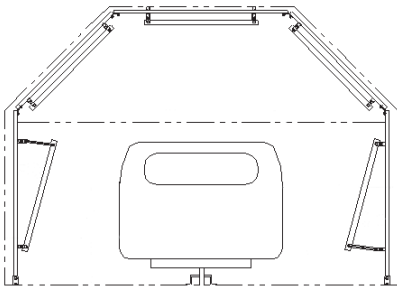

Pivot mount or stationary mounting brackets allow aiming of fixtures for optimal performance.
NOTE: Not available for INS2 fixtures.

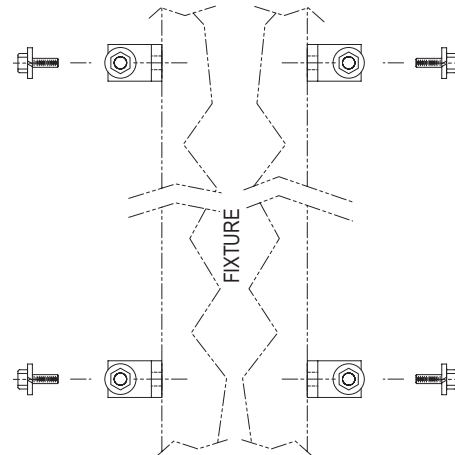

P/N 3564 Stationary Mount Kit
4 Ft. and 8 Ft.
Fluorescent Inspection Lighting

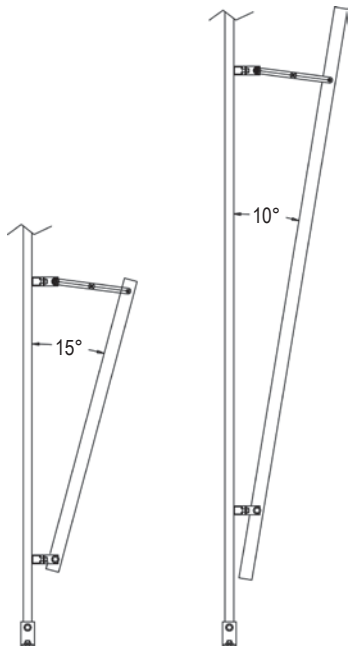

4 Foot Fixture Rotation 8 Foot Fixture Rotation

P/N 3563 Pivot Hinge Mount Kit 4 Ft. and 8 Ft.
Fluorescent Inspection Lighting

INSPECTION CART SWIVEL MOUNT
P/N 4828 Swivel Mount Kit
(For mounting fixtures on a 2" square tube frame. For use on 4 Ft. fixtures only.)

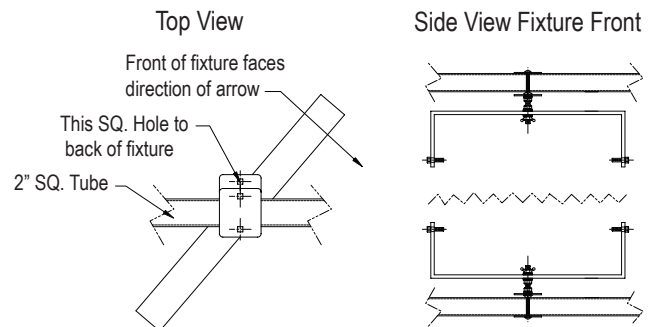

INSPECTION TUNNEL



www.ldpi-inc.com

FOR LDPI, Inc. INSPECTION FIXTURES

STANDARD INSPECTION TUNNEL

LDPI's Inspection Tunnel provides visual angles from all sides and can be designed with combinations of 4 Ft. and 8 Ft. fixtures to fit product and application requirements.

1. Unistrut is 1 5/8" square
Minimum 16 gauge
Choice of galvanized or painted green
2. All pieces are bolt-together
3. Strut pieces supplied cut to length
unless specified otherwise.
4. Tunnel will need to be bolted or welded
to existing structure*
5. Fixtures mounted 26 1/2" on center

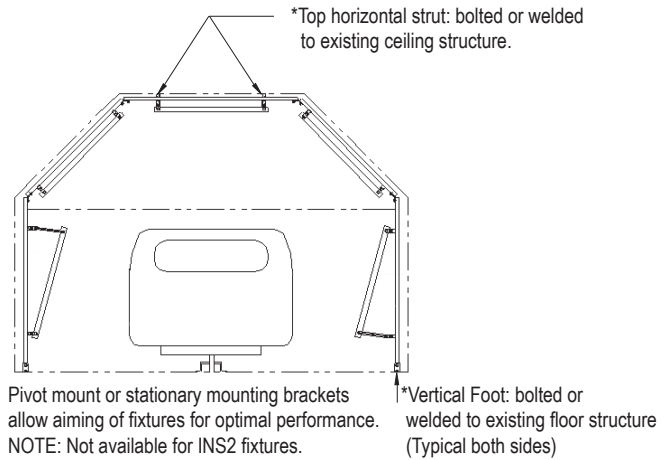

NOTE: Recommended ambient light level of 20-25 foot-candles outside the tunnel.

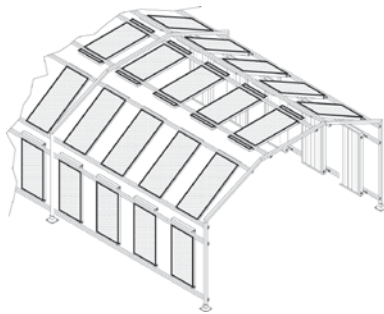

4 Ft. fixture top horizontal mount

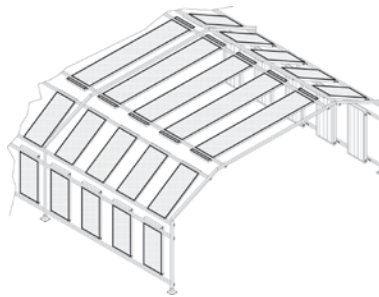

8 Ft. fixture top horizontal mount

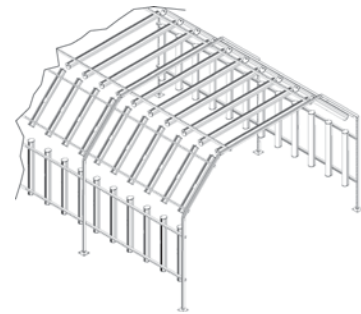

INS2 with 8 Ft. fixture top horizontal mount



Standard Inspection Tunnel



Standard Inspection Tunnel with pivot mounts