



# 229H SERIES

GENERAL INDUSTRIAL LIGHTING

DATE: _____	PROJECT MGR: _____
JOB: _____	
CAT#: _____	
TYPE: _____	



TASK	1
PAINTBOOTH	2
VAPOR DUST	3
VAPOR	4
WET DAMP	5
MARINE	6
EXPLOSION PROOF	7
HID	8
INSPECTION	9
PORTABLE LIGHTING	10
MOUNTING	11
PHOTOMETRY	12
LAMPS BALLASTS	13
INFO	14
CUSTOM	15
ASK THE EXPERT	16

## DESCRIPTION

Fabricated from prepainted cold rolled steel, the Series 229H is ideal for a variety of industrial lighting needs. A unique hinged ballast cover provides easy access to internal wiring and ballast for installation or service without the need to remove lamps. The Series 229H uses a 5 Ft. 3-wire whip which reduces installation time by not having to open the fixture. Available in T12, T8, T8HO, or T5HO lamps.

## SPECIFICATIONS

- LISTINGS:** UL1598 
- FEATURES:** Heavy Duty open industrial fixture.  
Hinged ballast plate allows for the fixture to be lamped prior to installation.  
Sturdy 20-gauge steel with durable prepainted white enamel finish.
- ELECTRICAL:** Utilizes 32, 40, 44, and 54 Watt 4' lamps.  
Available in Universal, 120, 277 and 347 Volt electronic ballasts.  
(Other voltages available, consult factory)
- APPLICATIONS:** General Lighting
- OPTIONS:** **All Options Ordered Separately**  
A: Pattern 12 acrylic diffuser available in 32W T8 only.  
WG: Zinc plated wire guard  
PC: Post Painted Polyester White Powder Coat Paint  
EM: Emergency Battery Backup Ballast  
120 or 277V **MUST SPECIFY**  
2 or 3 Lamp options.  
Installed lamps (lamps sold separately)
- **MOUNTING KITS - Ordered Separately**  
Chain Hanging Kit - #3218

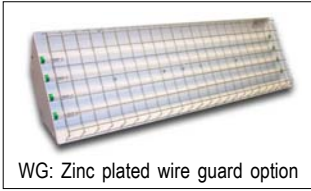



# 229H SERIES

## GENERAL INDUSTRIAL LIGHTING

### PART NUMBERS

- 1 TASK
- 2 PAINTBOOTH
- 3 VAPOR DUST
- 4 VAPOR
- 5 WET DAMP
- 6 MARINE
- 7 EXPLOSION PROOF
- 8 HID
- 9 INSPECTION
- 10 PORTABLE LIGHTING
- 11 MOUNTING
- 12 PHOTOMETRY
- 13 LAMPS BALLASTS
- 14 INFO
- 15 CUSTOM
- 16 ASK THE EXPERT

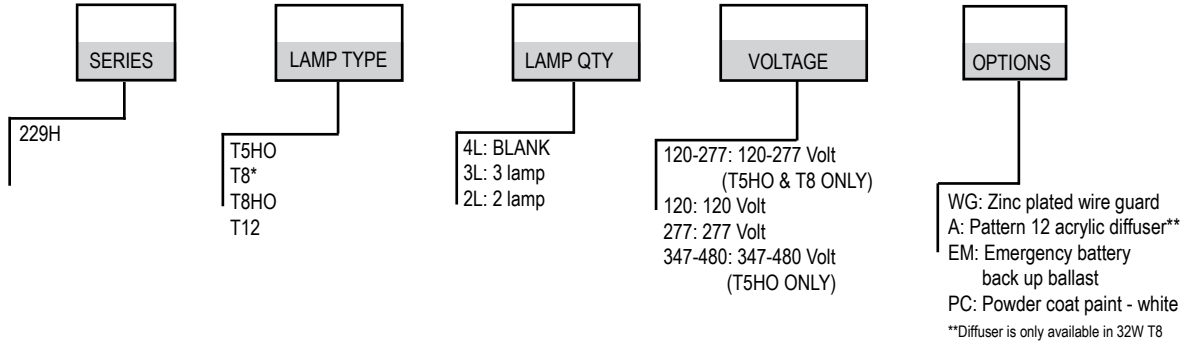

LAMPS SOLD SEPARATELY  
 (Multiple voltages available, consult factory)  
 \*Normally stocked fixture  
 (Consult factory for lead time on non-stock products.)



### DIMENSIONS

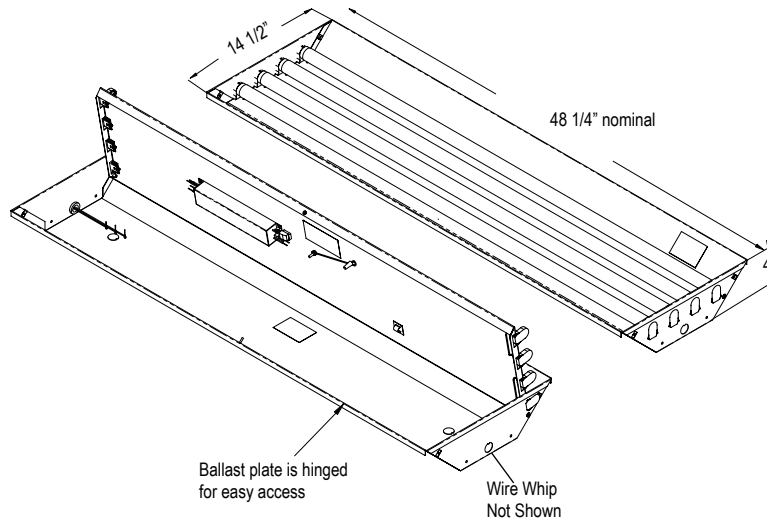

### MOUNTING - ORDERED SEPARATELY

PN: 3218 Chain hang kit

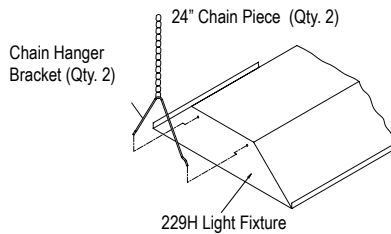



# MOUNTING

FOR LDPI, INC. FIXTURES

## 229H Series

PN: 3218 Chain hang kit

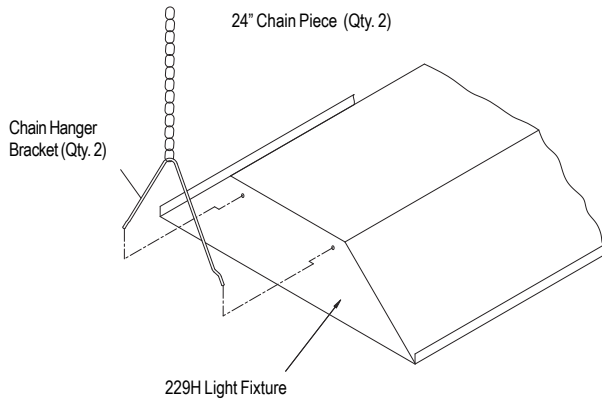

TASK ①

PAINTBOOTH ②

VAPOR DUST ③

VAPOR ④

WET DAMP ⑤

MARINE ⑥

EXPLOSION PROOF ⑦

HID ⑧

INSPECTION ⑨

PORTABLE LIGHTING ⑩

**MOUNTING ⑪**

PHOTOMETRY ⑫

LAMPS BALLASTS ⑬

INFO ⑭

CUSTOM ⑮

ASK THE EXPERT ⑯